

SPECIFICATIONS

GRAPHIC PANEL SIZES

Finished graphic panel size

2300 x 1500mm

[Includes 200mm bleed]

Visual graphic area

2100 x 1500mm

SYSTEM SIZES

Boxed size

1535 [l] x 220 [w] x 95 [d]mm

Assembled size

1520 [w] x 165 [d] x 2120 [h]mm

BOXED WEIGHTS

Single-sided

7.27kg

Double-sided

9.0kg

NOTE: Please test your substrate suitability before use.

COMPONENT LIST

1x Sidewinder unit complete with poles

Graphic hanger

– 1x hanger [single-sided unit]

– 2x hangers [double-sided unit]

Hook fastener

– 1x strip [single-sided unit]

– 2x strips [double-sided unit]

1x Hanger support [double-sided unit]

1x Padded carry bag

FRESCO
graphic displays

SIDEWINDER BANNER STAND ASSEMBLY INSTRUCTIONS

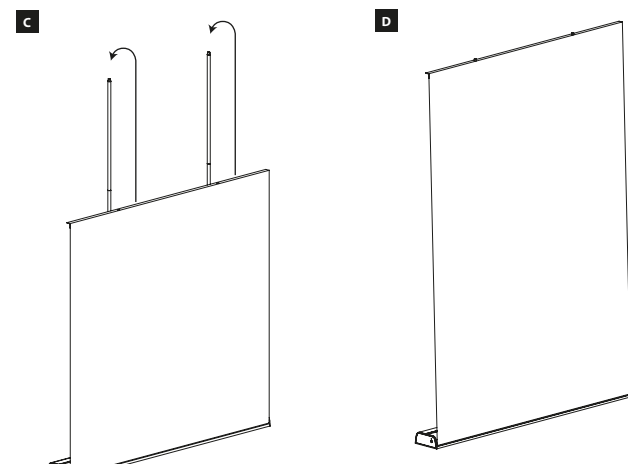
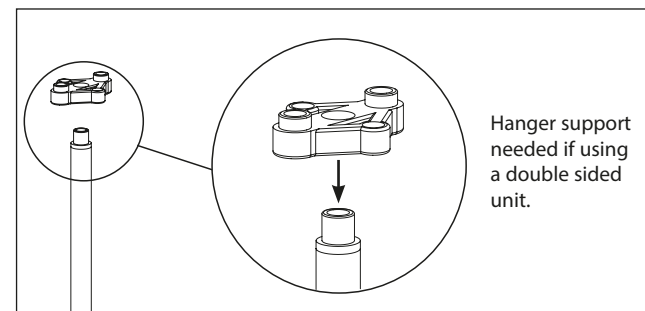
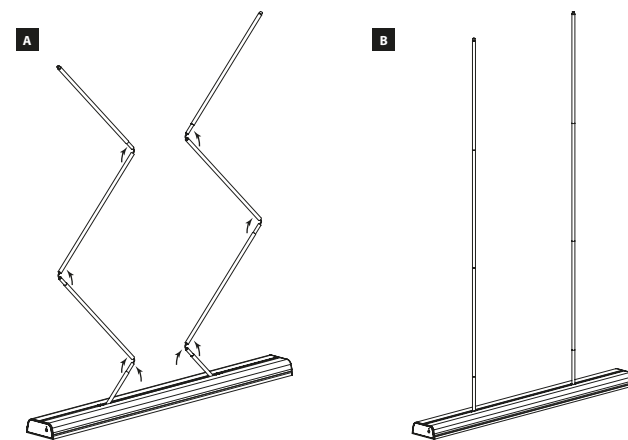

IMPORTANT NOTICE:

When retracting a graphic always slowly guide it into base housing, otherwise graphic damage may occur.

GRAPHIC ATTACHMENT

A Attach top rear of graphic panel to double sided tape on top hanger.

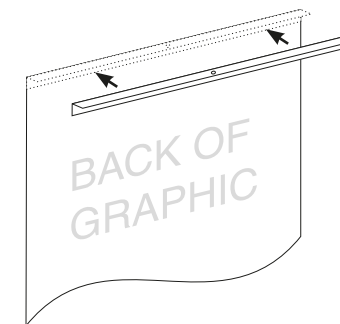

B Attach hook fastener to front bottom edge of graphic.

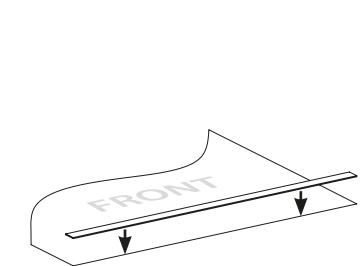

C Attach front bottom edge of graphic panel to loop fastener on leader sheet, as shown.

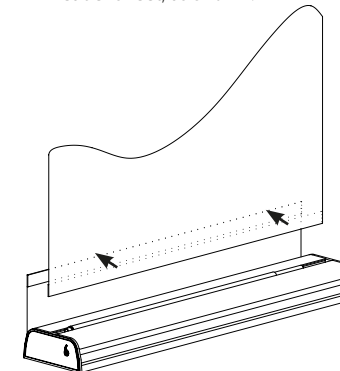

D Holding onto graphic, remove locking pin and allow graphic to slowly retract into unit.

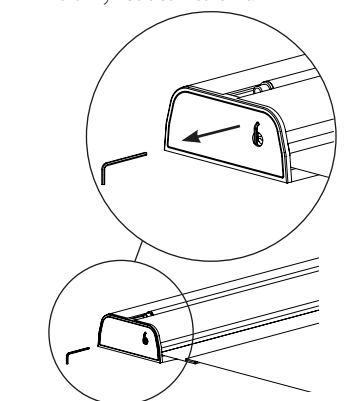

ADDING OR REMOVING GRAPHIC TENSION

ADDING TENSION

Insert a standard flat headed screwdriver into slot located in the end of unit and turn clockwise to add extra graphic tension.

REMOVING TENSION

To un-tension graphic panel place a flat headed screwdriver into the slot and push to disengage ratchet. Hold in and turn anti-clockwise until tension in spring is released. To remove graphic panel carefully peel it off leader sheet. The graphic hanger can also be removed or a new hanger can be purchased.

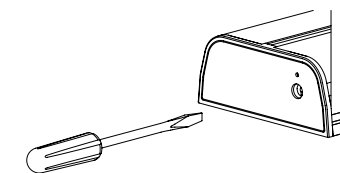

IMPORTANT NOTICE:

To ensure a proper bond between graphic and double sided tape pressure must be applied. The adhesive should be allowed to cure for 24 hours before tension is applied.